

DCLI

Deeter Current-Loop Indicator User Manual.

Packing list

Open the outer carton and check all parts listed below are enclosed and undamaged.

- The Indicator Module.
- The User Manual.

If any parts are missing or damaged please contact the Deeter Group at:

In Europe

Deeter House,
Valley Road,
Hughenden Valley,
Bucks.
HP14 4LW
Tel: +44 (0)1494 566046
Fax: +44 (0)1494 563961
Email: sales@deeter.co.uk

In the USA

446
Commerce Street
Tallmadge
Ohio
44278
Tel: 001 330 630 3510
Fax: 001 330 630 3512
Sales@deeterelectronicsinc.com



Warnings ⚠

- Power down all connected equipment before making any connections to the display unit.
- Take care not to damage the connected wires when inserting the display in the mounting panel.
- Do not attempt to repair this product yourself.
Contact the Deeter Group for product servicing or repairs.
- This device is not water proof.
- Do not touch the electronic circuit should it become exposed.
- When disposing of this product, do so in accordance with your local waste disposal regulations.



General

The DCLI (Deeter Current-Loop Indicator) is an easy to mount display module designed to work with any 4-20mA current loop process sensor. A 0-20mA option is provided and can be selected during calibration setup. The integral display consists of four 7-segment LED's capable of showing values between -999 and 9999 with a selectable decimal point position. Any number in this range can represent the minimum current and any other number, the maximum current, thus the display may represent a wide variety of measurement units and may also be configured to represent an inverted 20-4mA current if desired.

The module incorporates two relays with normally-closed contacts which can be individually configured to open and close at any display threshold. Separate ON and OFF settings allow the amount of hysteresis to be chosen and depending on whether the ON setting is higher or lower than the OFF setting, the relays can be chosen to either open-high/close-low or open-low/close-high. - see diagrams below.

Relay ON threshold greater than the OFF threshold

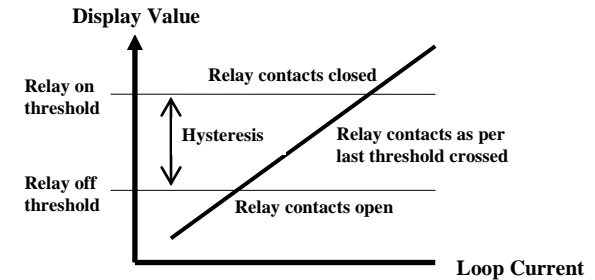

Relay ON threshold less than the OFF threshold

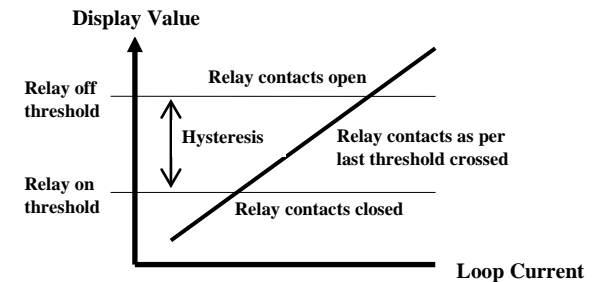

Wiring

Please refer to the unit label if the screw terminal layout is different to that shown below.

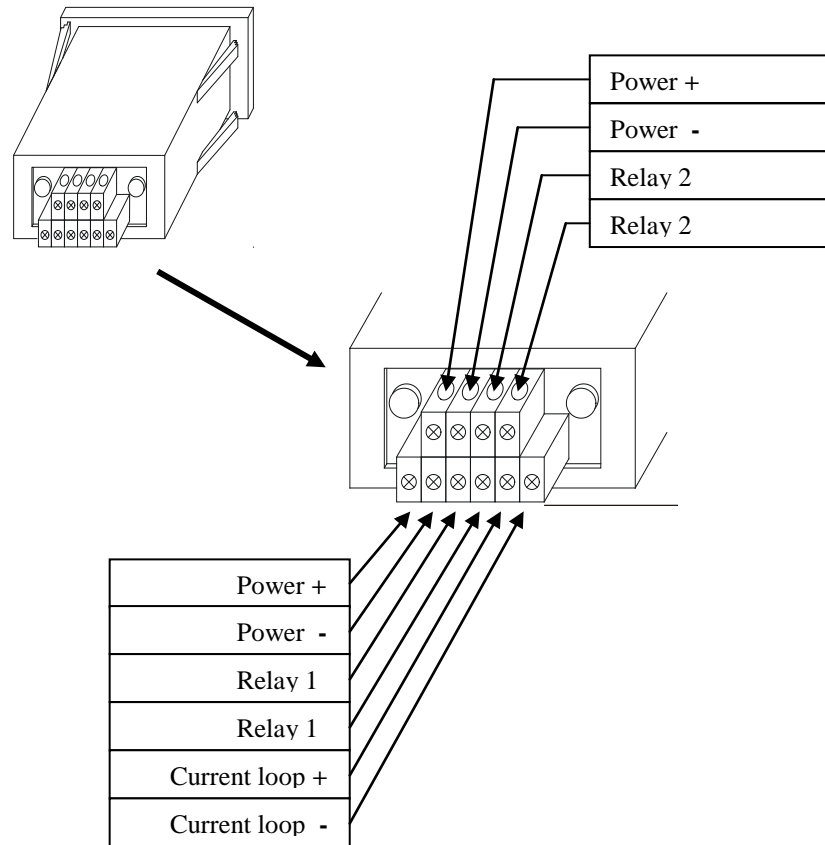

Calibration

The display module must be powered and connected to a current-loop source before calibration can begin. The relays do not require connecting during calibration or relay setup. Calibration and relay settings are configured using the 2 buttons at the rear of the module.

Settings are saved to a non-volatile memory and are reinstated after power-up. Re-calibration may be required if additional equipment is added to the current-loop circuit at a later stage.

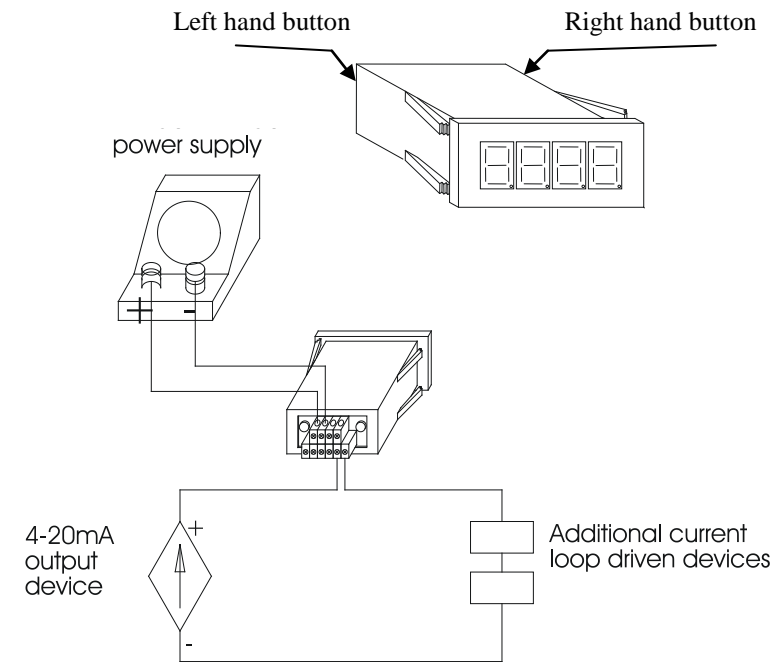

The displayed output is assumed to have a linear relationship with the input. Therefore, calibration requires recording just two input levels and selecting the desired displayed output for these inputs. Any two inputs could be used, but for greatest accuracy they should be as far apart as possible. 4mA and 20mA settings are assumed in the following example, but the actual inputs can differ.

Display calibration and setup procedure

- Press and hold down the right-hand button for 2 seconds. The display will show 'CAL1'.
- Adjust the loop current to the module to 4mA.
- Press and hold the right-hand button for 2 seconds. The display will show '0' to represent the displayed output for the 4mA input.
To increment or decrement the display, press and hold the left-hand button. Rapid change will start after 2 seconds and gradually increase in speed if the button is continually held down.
- To toggle between increment and decrement, press and release the right-hand button.
- When the desired display output has been selected for the 4mA loop current, press and hold the right-hand button for 2 seconds. The display will show 'CAL2'
- Adjust the loop current to the module to 20mA. Press and hold the right-hand button for 2 seconds. The display will show '0' to represent the displayed output for the 20mA input.
- Repeat the process for setting the displayed output, as above.
Press and hold the right-hand button for 2 seconds. The display will show '.dp'
- Choose the desired decimal point position (or decimal point off) by pressing the left-hand button.
- Press and hold the right-hand button for 2 seconds. The display will show '4or0'. Press the left-hand button to toggle the decimal point between 4 and 0. This selects the 4-20mA or 0-20mA operation.
- Press and hold the right-hand button for 2 seconds to save and complete the calibration mode.
- Vary the current input to check the display is configured as required before moving on to setting the relays. The display will show 'Hi' or '-Lo' for values outside the display range.

Relay setup procedure

- The relays are configured to turn on or off at display thresholds, not the loop current.
- Press and hold the left-hand button for 2 seconds to enter the Relay Setup Mode.
- The display will show 'r1.on' representing Relay1 ON, for a short while, then show the present setting..
- To increment or decrement the setting, press and hold the left-hand button. Rapid change will start after 2 seconds and gradually increase in speed if the button is continually held down.
- To toggle between increment and decrement, press and release the right-hand button.
- When the required setting has been selected, press the right-hand button for 2 seconds to advance to the next stage.
- Use the above method to set all 4 relay thresholds; r1.on (Relay1 ON), 1.off (Relay1 OFF), r2.on (Relay2 ON) and 2.off (Relay2 OFF).
- When relay setup has been completed the display will show 'donE' for 2 seconds and then return to normal operation.

Mounting

The display module is enclosed in a black plastic box with a tough dark red translucent face plate.

When mounted, only the face plate protrudes above the mounting panel by a height of 7mm.

A 69.3mm x 29.3mm square aperture should be cut into the mounting panel with a 4mm clear border around the hole.

The module is designed with 4 flexible retaining arms which will grip when mounted into a panel thickness of

11 Gauge 2.95mm [0.116"]

14 Gauge 2.03mm [0.080"]

16 Gauge 1.63mm [0.064"]

Once mounted the module can easily be removed by squeezing together the flexible arms and pushing the module out of the mounting panel.

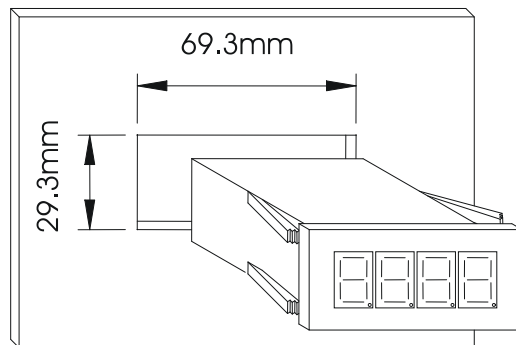

Specification

Supply voltage range	7 to 26Vdc
Supply current	<100mA
Current loop voltage	30Vdc Max
Current loop range	1mA to 21mA. (0mA to 21mA for the 0-20mA option)
Current loop resistance	100Ω
Relay contacts	Normally-open (Form A) 48Vac/dc 0.5A
Operating temperature	-5° to +60°C
Display range	-999 to 9999
Display linearity*	±0.1%
Environmental	IP40. IP55 when fitted to a suitable enclosure

* To ensure maximum accuracy, calibrate using the full 4mA to 20mA current-loop range.

* Re-calibrate if additional equipment is added to the current loop.

Display Messages

- 'HI' Display value greater than +9999
- '-LO' Display value less than -999
- 'OPEn' Loop current less than 1mA (4-20mA option only)
- 'OVER' Loop current greater than 21mA
- 'dxxx' Start up firmware revision, where xxx=revision number.

Other messages will be displayed during display calibration and relay setup modes.