

DCLIB

Deeter Current-Loop Indicator – Bargraph User Manual.

Packing list

Open the outer carton and check all parts listed below are enclosed and undamaged.

- The Indicator Module.
- The User Manual.

If any parts are missing or damaged please contact the Deeter Group at:

In Europe

Deeter House.

Valley Road,
Hugghenden Valley,
Bucks.

HP14 4LW

Tel: +44 (0)1494 566046

Fax: +44 (0)1494 563961

Email: sales@deeter.co.uk

In the USA

446

Commerce Street
Tallmadge

Ohio

44278

Tel: 001 330 630 3510

Fax: 001 330 630 3512

Sales@deeterelectronicsinc.com

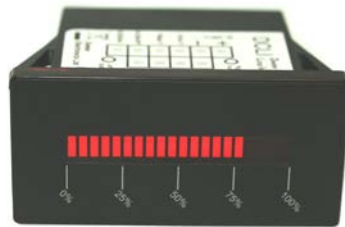

Warnings



- Power down all connected equipment before making any connections to the display unit.
- Take care not to damage the connected wires when inserting the display in the mounting panel.
- Do not attempt to repair this product yourself. Contact the Deeter Group for product servicing or repairs.
- This device is not water proof.
- Do not touch the electronic circuit should it become exposed.
- When disposing of this product, do so in accordance with your local waste disposal regulations.



General

The DCLIB (Deeter Current-Loop Indicator – Bargraph) is an easy-to-mount display module designed to work with any process sensor with a 4-20mA output. The DCLIB will also operate down to 0mA for a 0-20mA system.

The display consists of a row of 20 LED's that indicate 5% increments in loop current. (The relation between loop current and display is assumed to be linear). There are two modes of operation, 'Scrolling' and 'Rolling'. In Scrolling mode the number of bars change to indicate the loop current (like a scroll unwinding), whereas in Rolling mode only one LED is on at a time, its position indicating the loop current. Scrolling would typically be used to indicate liquid level and Rolling mode used with a position sensor.

The module also incorporates two normally-open relays. These can be individually configured to open and close at any display threshold. Separate ON and OFF settings allow the amount of hysteresis to be chosen, and depending on whether the ON setting is higher or lower than the OFF setting, the relays can be chosen to either open-high/close-low or open-low/close-high. - see diagrams below.

Relay ON threshold greater than the OFF threshold

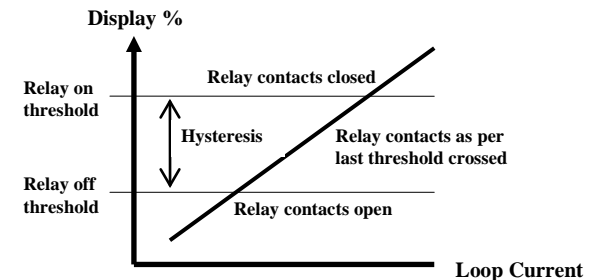

Relay ON threshold less than the OFF threshold

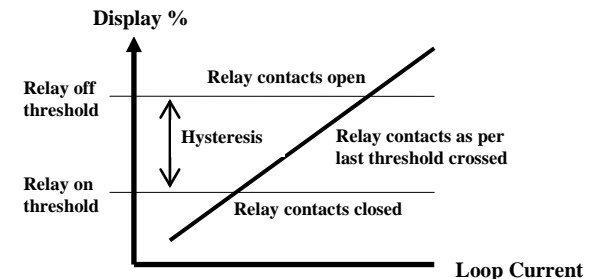

Wiring

Please refer to the unit label if the screw terminal layout is different to that shown below.

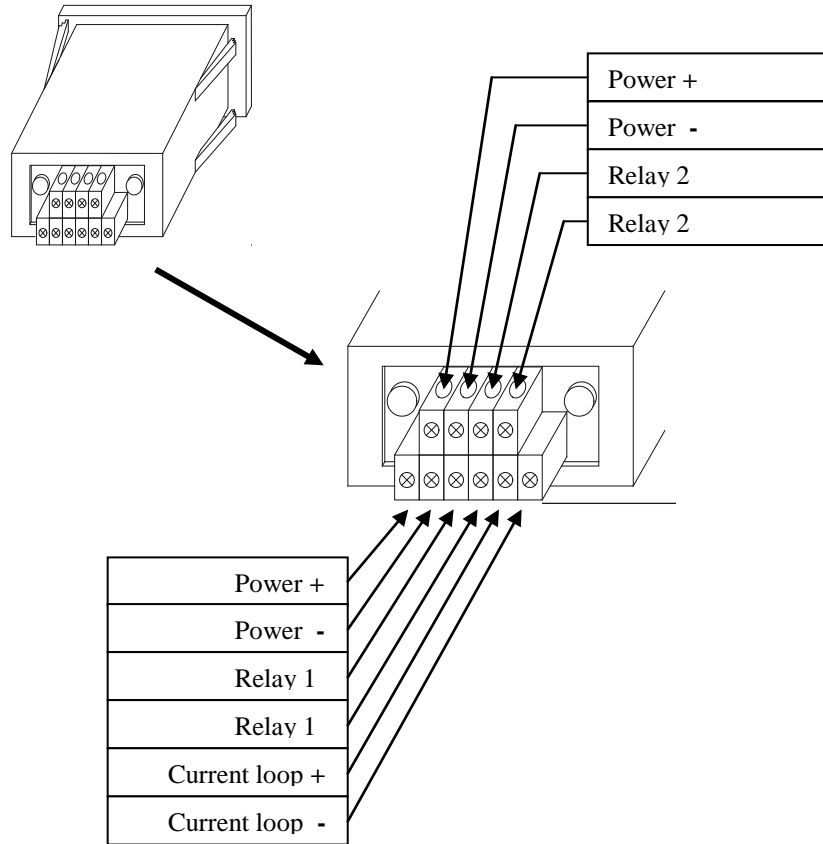

Calibration

The display module must be powered and connected to a current loop source before calibration can begin. The relays do not require connecting during calibration. Calibration and relay settings are configured using the 2 buttons at the rear of the module.

Settings are saved to a non-volatile memory and are reinstated after power-up. Re-calibration may be required if additional equipment is added to the current-loop circuit at a later stage.

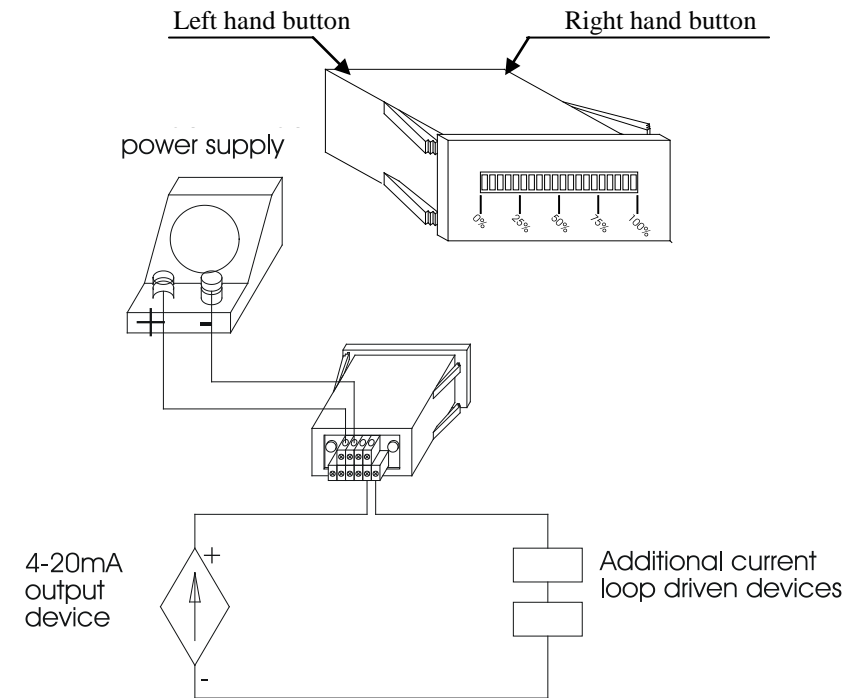

The displayed output is assumed to have a linear relationship with the current-loop input, therefore calibration requires recording just two input levels – the current that represents the 0% level and the current that represents 100%.

Display calibration and mode selection procedure

- Press and hold down the right-hand button for 2 seconds. The display will slowly flash the first (0-5%) bar.
- Adjust the loop current to the level that represents 0% (typically this would be 4mA).
- Press and hold the right-hand button for 2 seconds. The display will slowly flash the last (95-100%) bar.
- Adjust the loop current to the level that represents 100% (typically this would be 20mA).
- Press and hold the right-hand button for 2 seconds. The display will now scroll from left to right and back again. This is the default Scrolling display option. To toggle between Scrolling and Rolling modes, press the left-hand button. Rolling mode will be shown by a single bar moving left to right and back again.
- Having selected the appropriate display mode, press and hold the right-hand button for 2 seconds to complete the calibration and display setup. It is at this point that settings are saved to non-volatile memory, so powering off and back on at a previous step will recover prior settings.
- Vary the loop current to check the display is configured as required before moving on to setting the relays.

Relay setup procedure

- The relays are configured to turn on or off at displayed output thresholds, not the loop current.
- Press and hold the left hand button for 2 seconds to enter Relay Setup Mode.
- The display will slowly flash the first (0-5%) bar and show a steady bar at the present Relay1 ON threshold. (If the present threshold coincides with the first bar, the bar will flash between half and full brightness.)
- To view settings without making changes, do not press the left-hand button; advance with the right-hand button only.
- To increment the relay threshold, repeatedly press the left-hand button. After reaching the last (95-100%) bar the setting will go back to the first bar.
- When the required display threshold has been selected (or if just viewing the settings), press and hold the right-hand button for 2 seconds.
- The display will slowly flash the second (5-10%) bar and show the present Relay1 OFF threshold with a steady bar.
- Repeat the use of the left-hand button to select a new threshold and the right-hand button to save and advance to the next settings – for Relay1 OFF (2nd bar flashing), Relay2 ON (3rd bar flashing) and Relay2 OFF (4th bar flashing).
- After Relay2 OFF, the display will return to normal operation. It is at this point that settings are saved to non-volatile memory so powering off and back on before this stage will recover prior relay settings.

Firmware revision indication

On power-up the display will flash a few times before settling into normal display mode. The bars that flash indicate the firmware revision. The flash rate is much faster than the flashes used during Calibration or Relay setup procedures and will last just a few seconds.

Mounting

The display module is enclosed in a black plastic box with a tough dark red translucent face plate.

When mounted, only the face plate protrudes above the mounting panel by a height of 7mm.

A 69.3mm x 29.3mm square aperture should be cut into the mounting panel with a 4mm clear border around the hole.

The module is designed with 4 flexible retaining arms which will grip when mounted into a panel thickness of

11 Gauge 2.95mm [0.116"]

14 Gauge 2.03mm [0.080"]

16 Gauge 1.63mm [0.064"]

Once mounted the module can easily be removed by squeezing together the flexible arms and pushing the module out of the mounting panel.

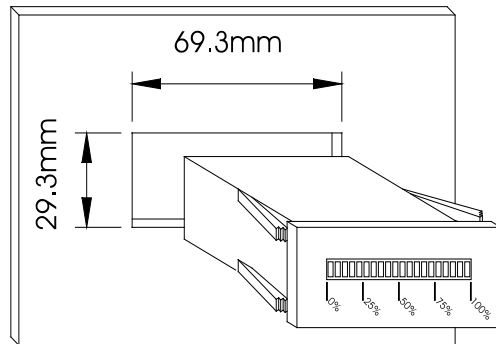

Specification

Supply voltage range	7 to 26Vdc
Supply current	<100mA
Current loop voltage	30Vdc Max
Current loop range	0mA to 21mA
Current loop resistance	100Ω
Relay contacts	Normally-open (Form A) 48Vac/dc 0.5A
Operating temperature	-5° to +60°C
Current Measurement Accuracy *	±0.2%
Display Range and Resolution	1 bar (<5%) to 20 bars (>95%) in 5% steps
Environmental	IP40 IP55 when fitted to a suitable enclosure

* Accuracy is dependent on the current-loop range used for calibration. The figure shown assumes a range of 16mA (e.g. 4-20mA).

* Re-calibrate if equipment is added to or removed from the current loop.