

Ultrasonic Level Meter SLM1000 Series

(USER'S MANUAL)



IS Technologies Co., Ltd.

SLM1000 SERIES

March 2003

COPYRIGHT

© IS Technologies Co., Ltd. All rights reserved. No part of this publication may be reproduced, transmitted, transcribed, stored in a retrieval system, or translated into any language in any form without the written permission of IS Technologies Co., Ltd.

WARRANTY AND LIABILITY

IS Technologies Co., Ltd. guarantees for a period of 1 year from the date of delivery that it will either exchange or repair any part of this product returned to IS Technologies Co., Ltd. if it is found to be defective in material or workmanship, subject to the defect not being due to unfair wear and tear, misuse, modification or alteration, accident, misapplication or negligence.

DISCLAIMER

IS Technologies neither gives nor implies any process guarantee for this product, and shall have no liability in respect of any loss, injury or damage whatsoever arising out of the application or use of any product or circuit described herein. Every effort has been made to ensure accuracy of this documentation, but IS Technologies cannot be held liable for any errors.

TECHNICAL ENQUIRIES

Please contact IS Technologies Co., Ltd. for technical support.

IS Technologies Co., Ltd.

203/504 Buchon Techno Park, 192, Yakdae Dong, Wonmi Gu, Buchon City Kyungki, Korea

Tel: 82-32-621 2606 Fax: 82-32-621 2612

Web Site: <http://www.sondar.com>

e-mail: sales@sondar.com

Contents

- Chapter 1 Product Specification4

- Chapter 2 Installation.....5
 - Power Supply Requirements5
 - Dimensions6
 - Terminal Connection6
 - Outdoor and Open Vessel Application.....8
 - Closed Vessel Application.....8
 - Stand Pipe Application.....8

- Chapter 3 How To Use Controller9
 - Operating the Controller.....9

- Chapter 4 Menu Guide.....11
 - Application Menu Options11
 - Process Menu Options.....13
 - Compensation Menu Options16

- Chapter 5 Digital Communication.....19

- Chapter6 Trouble Shooting.....20

- Menu Option Record.....21

Chapter 1 Product Specification

Product Composition

SLM800S : SLM1000(CONTROLLER) + XDS800(SENSOR)

SLM1200S : SLM1000(CONTROLLER) + XDS1200(SENSOR)

SLM1500S : SLM1000(CONTROLLER) + XDS1500(SENSOR)

Physical

Dimensions	Controller	240 (width). x 185 (height) mm = SLM1000(Controller)
	Sensor	67 (dia) x160 (height) mm = XDS800 88 (dia) x 100 (height) mm = XDS1200 101 (dia) x 120 (height) mm = XDS1500
	Mounting	3/4"NPT(XDS800), 1"NPT(XDS1200, XDS1500)
	Weight	Nominal 3.0 kg
	Sensor material	PP(XDS800), PVC(XDS1200, XDS1500), STS(XDS800-Option)

Environmental

IP Rating (electronics housing)

IP65

Max. & Min. temperature (electronics)

-20 °C to +70 °C

Performance

Accuracy 0.35% of the measured range

Resolution 1mm

Max. range Liquids 8m/12m/15m

Min. range 0.35meter / 0.50 meter (XDS1200/XDS1500)

Beam Angle 10° at -3dB

Damping Rate Adjustable from 0.1m/min to 100m/min

Temperature Compensation Fully compensated via integral temperature sensor over entire operational span

Explosion Proof EEX d II T6

Outputs

Analogue output 4-20mA into Max 600Ω (user adjustable) Fault condition Alarm 3.8mA
or 21mA user selectable.

Display 2 Line 40 Characters LCD

Programming

On-board programming via 4 tactile push button keys

Supply

Power supply AC 90 ~ 260V, DC 12/24V

Chapter 2 Installation

Power Supply Requirements

The SLM1000 Series operate from an AC supply of 90 –260V or DC 12/24V.

All electronic products are susceptible to electrostatic shock, so follow proper grounding procedures during installation.

The construction of the SLM1000 Series can be mounted easily using the thread (3/4" NPT, 1"NPT).

When choosing a location to mount the XDS800/1200/1500(Sensor), bear in mind the following:

- For easy access to the LCD display and programming buttons mount it where it is easily accessible.
- The ultrasonic signal path should be free of falling material and obstructions such as pipes, beams etc.
- The XDS800/1200/1500(Sensor) should be mounted at least 35/50cm above the maximum level of the material and be perpendicular to the surface.
- The mounting surface should be vibration-free.
- The ambient temperature of the sensor is between -20°C and 70°C.
- There should be no high voltage cables or electrical inverters close by.
- Do not use any metal substances when installing
(Please use the PVC nut & flange supplied as option)

Dimensions

XDS800/1200/1500

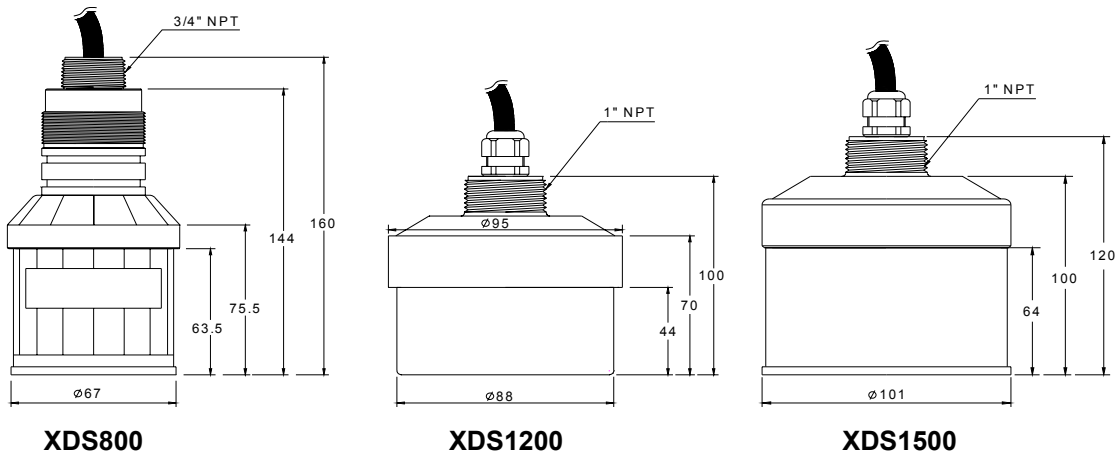

SLM1000

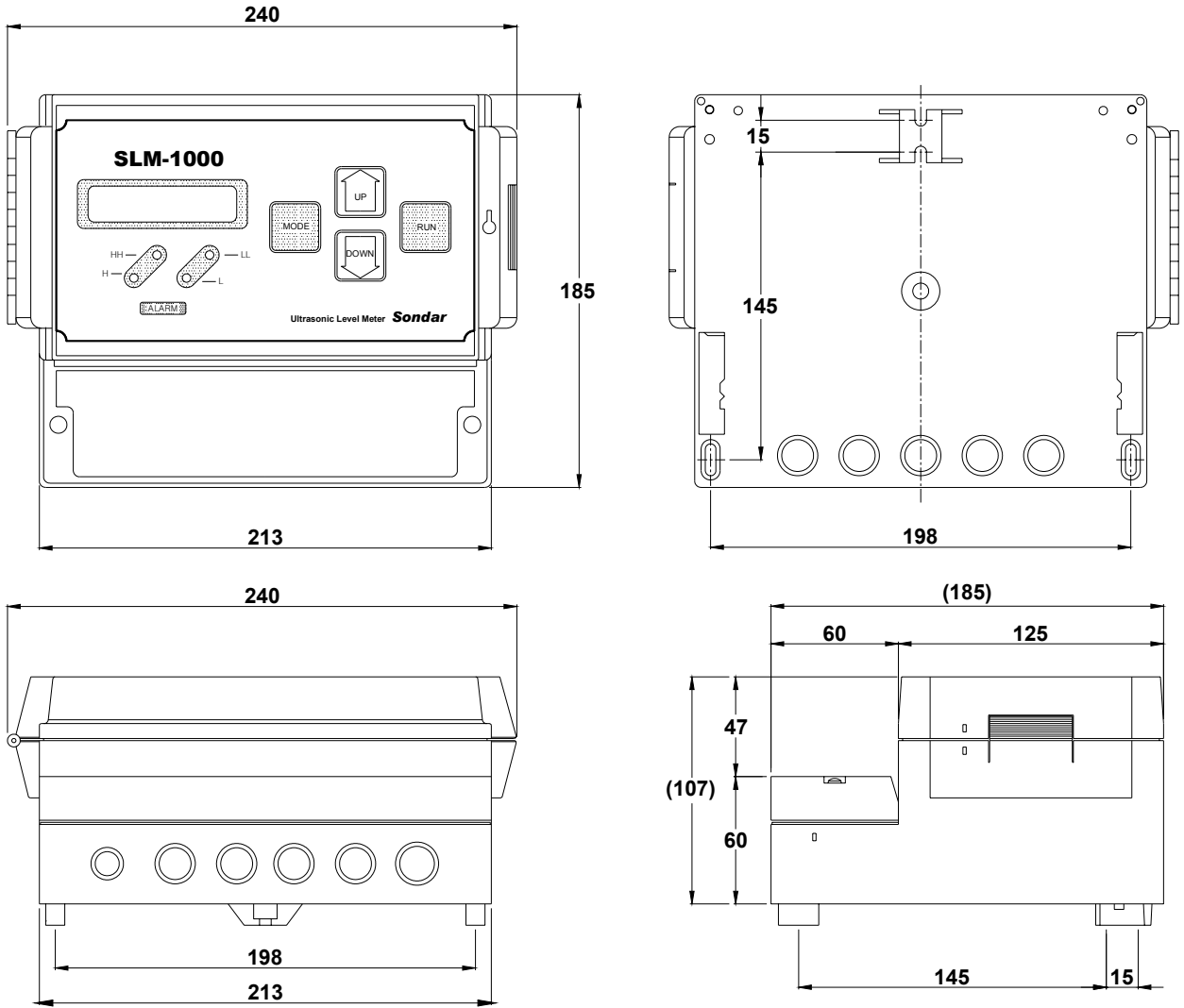

Terminal Connection

26 terminals are aligned inside the terminal box.

Input & Output Terminals

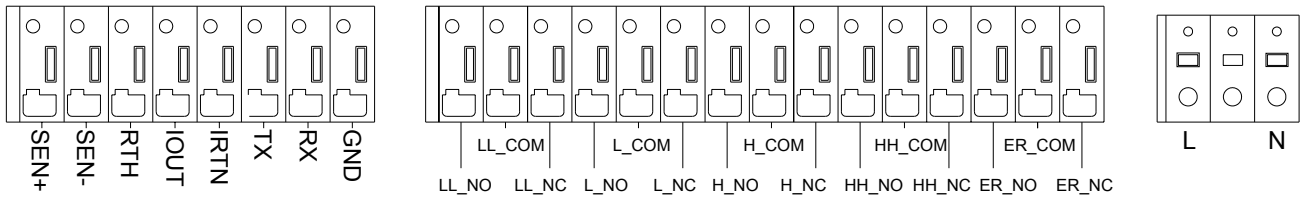

Function

Terminal	Function	Note
SEN+	Connect to positive wire(red) of ultrasonic sensor	
SEN-	Connect to shield wire(blue) of ultrasonic sensor	
RTH	This terminal is only used at factory	
IOUT	4~20mA current output	Maximum :600Ω
IRTN	Current output return	
TX	RS232C interface in use, connect to reception part RS485 interface in use, connect to Y	OPTION
RX	RS232C interface in use, connect to transmission part RS485 interface in use, connect to Z	OPTION
GND	GROUND, RX, TX	
LL_NO	Lower limit relay point, OFF with LL_COM together in operation	
LL_COM	Lower limit relay point, OFF with LL_NO together in operation	
LL_NC	Lower limit relay point, OFF with LL_COM together out of operation	
L_NO	Lower Alarm relay point, OFF with L_COM together in operation	
L_COM	Lower Alarm relay point, OFF with L_NO together in operation	
L_NC	Lower Alarm relay point, OFF with L_COM together out of operation	
H_NO	Upper Alarm relay point, OFF with H_COM together in operation	
H_COM	Upper Alarm relay point, OFF with H_NO together in operation	
H_NC	Upper Alarm relay point, OFF with H_COM together out of operation	
HH_NO	Upper limit relay point, OFF with HH_COM together in operation	
HH_COM	Upper limit relay point, OFF with HH_NO together in operation	
HH_NC	Upper limit relay point, OFF with HH_COM together out of operation	
ER_NO	Error relay point, OFF with ER_COM together in operation	
ER_COM	Error relay point, OFF with ER_NO together in operation	
ER_NC	Error relay point, OFF with ER_COM together out of operation	
L	Connect to line of AC power	
N	Connect to neutral of AC power	

Quantity of cables gland provided and the cable thickness

Model	Quantity	Thickness(ømm)
PG9	1	4~8
PG11	4	5~10
PG13.5	1	6~12

Outdoor and Open Vessel Installation

The XDS800/1200/1500 can be simply mounted on a bracket, suitable for the application and secured using the thread located at the top of the transducer (3/4"NPT, 1" NPT).

Care should be taken to ensure that the XDS800/1200/1500 are not installed in direct sunlight, in order to avoid errors in the measurement of ambient temperature.

Attention should also be taken, when mounting the unit, to ensure that strong windy conditions are avoided, wherever possible, to prevent abnormal operation.

Closed Vessel Installation

The XDS800/1200/1500 can be simply screwed into a flange and secured using the thread located at the top of the transducer (3/4"NPT, 1"NPT).

Where possible use a flange made of a synthetic material such as PVC, to avoid vibration. Place a rubber gasket between the flange and the connection to the vessel to avoid vibration.

Stand Pipe Installation

When mounting the XDS800/1200/1500 to a standpipe care should be taken to ensure that the standpipe is of sufficient dia with reference to its length, see the table below for details:

When using a standpipe, fixed to the top of a vessel, ensure that the open end of the standpipe is clear of any obstructions such as weld seams, gaskets etc. in order to avoid unwanted signal returns.

If using standpipes, which extend into the vessel, beyond the blanking distance, but not as far as the empty level, then the open end of the standpipe should be cut to an angle of 45°.

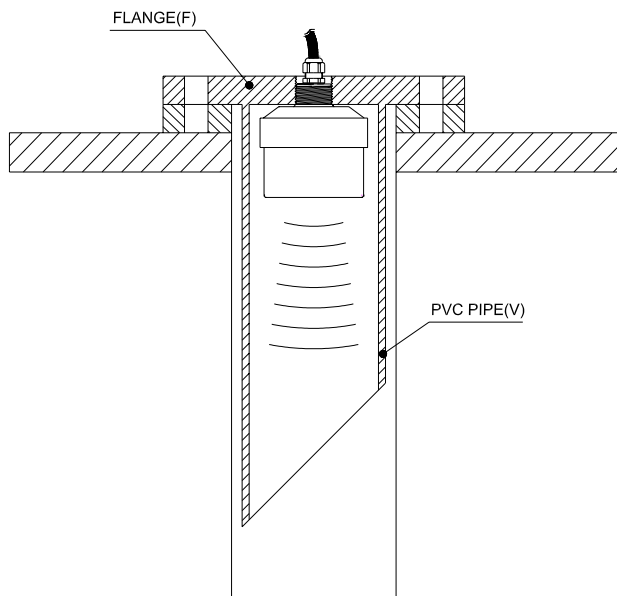

D [mm]	Maximum Length(mm)		
	XDS-800	XDS-1200	XDS-1500
80	300	305	300
100	380	380	380
150	570	570	570
200	760	760	760

Chapter 3 How To Use Controller

Operating the Controller

Display Window

SLM1000 is designed to display various data at the same time by adopting 40 letter LCD.

The display below shows an example of a normal operation of SLM1200S.

Conditions : The distance between the sensor and bottom of the tank : 12m

Current liquid level : 10m

L : 10.00 m	D : 2.00 m	D T
M : 86.9 %	TEMP : +24.5 °C	

- 1) L : 10.00 m : shows the current liquid level.
- 2) D : 2.00 m : shows the distance between the sensor and liquid level.
- 3) M : 86.9% : Percentage of the level
- 4) TEMP : Temperature around the sensor.
- 5) D : Indication of normal operation, shows returning echoes are well detected.
- 6) T : Indication of normal operation, shows tracking of returning echoes is okay.
- 7) S : No appearance under normal operation, but appears during abnormal operation such as abrupt level change. Searching for the returning echoes.

Setting Buttons

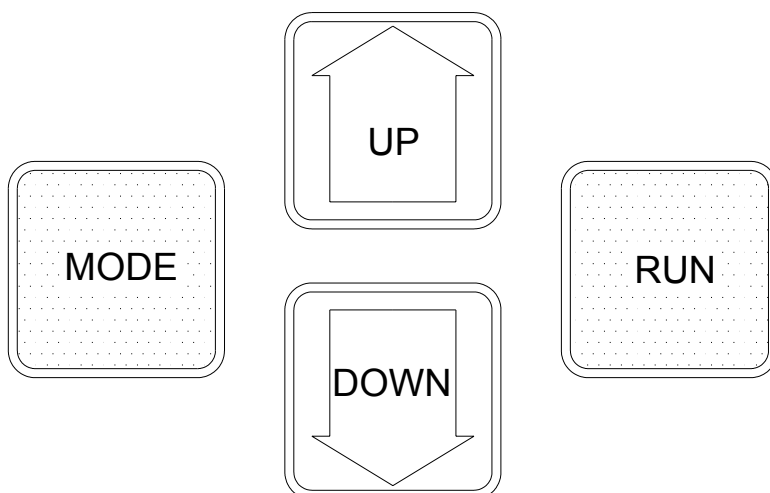

- 1) MODE Button : Used for entering program mode and saving values..
- 2) UP Button : Used for increasing the value.
- 3) DOWN Button : Used for decreasing the value.
- 4) RUN Button : Used for starting measurement.

Alarm Display



- 1)HH LED Lamp : Lighted in case of upper limit operated
- 2)H LED Lamp : Lighted in case of upper alarm operated
- 3)L LED Lamp : Lighted in case of lower alarm operated
- 4)LL LED Lamp : Lighted in case of lower limit operated

Application Menu Option

1) Password

PASSWORD IDENTITY
PASSWORD :

Password is needed to enter the operation mode.

After setting the password using UP/DOWN button, press MODE to get into the program mode. In case no password is changed, you can go to program mode by pressing MODE button.

- Password : 412

2) Measure Type

MEASURE TYPE SET
LEVEL

Factory Set = Level

This option sets the mode of operation when in measurement mode, and can be set to one of the following:

Option	Description
Level	Display shows how full the vessel is with respect to the Empty (0% of Span)
Distance	Display shows the distance from the transducer face to the surface.
Space	Display shows how an empty vessel is with respect to Full (100% of Span) i.e. how much space is available in the vessel.

Note!

This option determines current output value.

3) Bottom Distance

BOTTOM DISTANCE SET
BOT : 12.00m

FactorySet=8.00/12.00/15.00m

This option sets the maximum distance from the face of the transducer to the empty point

4) 4mA Setpoint

4mA POINT SET
4mA : 0m

Factory Set = 0

This option sets the distance (or level or space), depending on the selected **Measure Type** at which the 4mA output will occur. By default 4mA will represent **Empty**(0% of Span).

5) 20mA Setpoint

20mA POINT SET
20mA : 12.00m

FactorySet=8.00/12.00/15.00m

This option sets the distance (or level or space, depending on the selected **Measure Type** at which the 20mA output will occur. By default 20mA will represent **Full** (100% of Span)

Important Information

The Span is the maximum working distance from Empty (0%) to Full (100%), and is automatically calculated as Empty Level (Bottom Distance) minus Blanking Distance. Except for when Measure type = Distance in this case the Span is the same as the Empty Level

6) Blanking Distance

BLANKING DISTANCE
BL : 0.50m

FactorySet=0.35m~/0.50m~

This option is the distance from the face of the transducer that is not capable of being measured, and is pre-set to 35cm(SLM800S) or 50cm(SLM1200S/SLM1500S). It should not be set to less than this figure, but can be increased if required.

Process Menu Options

7) *HH ON Point Setting*

HH ON POINT SET
ON : 11.00m

This option determines the high limit "ON" point for HH relay

- Setting Range SLM800S - 0.35~8m
- SLM1200S - 0.5~12m
- SLM1500S - 0.5~15m

8) *HH OFF Point Setting*

HH OFF POINT SET
OFF : 10.00m

This option determines the high limit "OFF" point for HH relay

- Setting Range SLM800S - 0.35~8m
- SLM1200S - 0.5~12m
- SLM1500S - 0.5~15m

9) *H ON Point Setting*

H ON POINT SET
ON : 10.00m

This option determines the "ON" point for H relay

- Setting Range SLM800S - 0.35~8m
- SLM1200S - 0.5~12m
- SLM1500S - 0.5~15m

10) *H OFF Point Setting*

H OFF POINT SET
OFF : 9.00m

This option determines the "OFF" point for H relay

- Setting Range SLM800S - 0.35~8m
- SLM1200S - 0.5~12m
- SLM1500S - 0.5~15m

11) L ON Point Setting

L ON POINT SET
ON : 2.00m

This option determines the “ ON” point for L relay

- Setting Range SLM800S - 0.35~8m
- SLM1200S - 0.5~12m
- SLM1500S – 0.5~15m

12) L OFF Point Setting

L OFF POINT SET
OFF : 3.00m

This option determines the “ OFF” point for L relay

- Setting Range SLM800S - 0.35~8m
- SLM1200S - 0.5~12m
- SLM1500S - 0.5~15m

13) LL ON Point Setting

LL ON POINT SET
ON : 1.00m

This option determines the low limit “ON” point for LL relay

- Setting Range SLM800S - 0.35~8m
- SLM1200S - 0.5~12m
- SLM1500S - 0.5~15m

14) LL OFF Point Setting

LL OFF POINT SET
OFF : 2.00m

This option determines the low limit “OFF” point for LL relay

- Setting Range SLM800S - 0.35~8m
- SLM1200S - 0.5~12m
- SLM1500S - 0.5~15m

Important Information

The value of **HH relay ON point** should be higher than **OFF point** and this function is used for high limit.
The value of **LL relay ON point** should be lower than **OFF point** and this function is used for low limit
H, L relay are used for **pump control, draining control, high and low liquid level warning, etc.** at user’s need.

15) *Measuring Response*

MEASURE RESPONSE
RESP : 2

This option determines the maximum rate at which the unit will respond to an increase/decrease in level.

- Setting Range SLM800S - 0.35~8m
- SLM1200S - 0.5~12m
- SLM1500S - 0.5~15m

16) *Transmitting Power*

TRANSMITTING POWER
POW : 3

This option is used to set the power output from the transducer to suit varying applications. By reducing the power emitted the beam angle will be effectively reduced and can be applied as detailed below;

- Setting Range : 1 = Minimum Power
(For use on short range applications)
- 2 = Low Power
(For use on applications where obstructions such as pipes, beams, etc. are present)
- 3 = Normal Power
(For use in normal condition)
- 4 or 5 = High Power
(For use in arduous applications where conditions are dusty, steamy or turbulent)

17) *Error Current*

ERROR CURRENT SET
SET : 3.8mA

If the SLM800S/1200S fails to receive a valid echo return from the target, then the mA output can be used to indicate a fault condition (Lost of Echo)

- Setting Range : 3.8mA, 21mA, HOLD

18) *Fail Safe Time*

FAIL SAFE TIME
TIME : 120

In the event of a fail-safe condition occurring (Lost of Echo) the fail safe timer determines the time before the mA output indicates a fault condition (Lost of Echo)

Compensation Menu Options

19) Detection Threshold Voltage

DETECTION THRESHOLD
LEV : 4

This option determines detectable size of return echo. This is useful when the first return echo is needed in condition where small objects creating various kinds of return echoes exist. In case the set value is high, it can be stronger to the noise, but may not be able to detect small echoes. The 4 is equal to 0.3V. The table below shows the equivalent voltage to each value

No.	4	5	6	7	8	9	10	11	12	13	14	15
Voltage	0.3	0.5	0.7	0.9	1.1	1.3	1.5	1.7	1.9	2.1	2.3	2.5

20) Detection Method

DETECTION METHOD
METHOD : FIRST ECHO

This option determines detecting algorithm.

If " FIRST ECHO" is set, it will detect the first returned echo.

If " MAXIMUM ECHO" is set, it will detect the maximum echo among the returned echoes.

However, this method is used on the condition that the difference in voltage between the maximum echo and other echoes should be less than 0.5V. This method is useful where smaller objects are near the target.

21) Sound Velocity

SOUND VELOCITY SET
VELO : 331.5m/s

This option allows for the velocity of sound to be changed according to the atmosphere the transducer is operating in. By default the velocity is set for sound traveling in air at a temperature of 0°C.

The table below gives details of the velocity of sound in various gaseous atmospheres. In all cases the velocity indicated is that in a 100% gaseous atmosphere at 0°C. In atmospheres less than 100% it may be necessary to check the level indicated at near empty and near full and compare with the actual level, several times, then adjust the **Sound Velocity** accordingly to obtain an accurately displayed reading.

Gas	Sound Velocity
Chlorine	206 m/sec
Carbon Dioxide.	259 m/sec
Argon	308 m/sec
Oxygen	316 m/sec
Air	331.5 m/sec
Ammonia	415 m/sec
Methane	430 m/sec
Helium	435 m/sec
Neon	965 m/sec

22) Velocity Temperature Factor

VELOCITY TEMP FACTOR
FACTOR : 0.6m/°C

The sound velocity in air increases or decreases at fixed rate (0.6m/ °C)

This option allows the rate of change in m/°C to be set according to the present atmosphere and temperature. This option is useful where ambiguous or mixed gas exists. The newly set value should be compared with the actual level, several times, to obtain an accurately displayed reading.

- Setting Range : -2.0m/°C ~ 2.0m/°C

23) Material Temperature

MATERIAL TEMPERATURE
TEMP : 25.0°C

The SLM800S/1200S uses an internal temperature sensor, housed inside the transducer nose cone and therefore the temperature used for compensation is the temperature close to sensor. In applications where there is a large difference between the temperature near the sensor and that at the surface of the material being measured, errors in measurement may occur.

This mode allows for the present temperature at the material surface to be entered and reduces any error in measurement.

- Setting Range : 0~100.0

24) Material Temperature Weighting

MATERIAL T WEIGHTING
WET : 0%

This option is used in conjunction with **Mode 23, Material Temperature**. This option determines the effect the material temperature has on the air temperature in front of the transducer. Where the temperature of the material has no effect on the air temperature. **Mode 24** should be set to **0**, in which case **Mode 23, Material Temperature** will be ignored. However in cases where the material temperature heavily influences the temperature at the transducer **Mode 24** should be set to **100** and temperature compensation will be performed accordingly.

- Setting Range : 0~100

25) Measuring Unit

UNIT(FEET/METER)
METER

This option determines system unit.

- Setting Range : METER, FEET

26) 12mA Output

12mA OUTPUT

SLM800S/1200S outputs 12mA regardless of measurement at this mode.
This option is used with other equipments for testing.

Chapter 5 Digital Communication

The SLM1000 Series provides RS232/485 digital communication interface function as option

The kinds of data and its format are as follows;

Output Data

1. Kinds of Output Data

- 1) Distance Data
 - Distance from the sensor to the surface of measuring material. Unit is mm
- 2) Temperature Data
 - This is temperature data measured by built-in temperature sensor. Unit is 1°C

2. Data Format

Data is edited by ASCII and the sequence as follows

CR	LF	D						T	+, -			NUL
			10000	1000	100	10	1			10	1	
			Distance Data							Temperature Data		

- A. Baud Rate is 4800bps
- B. 1 Data Frame consists of Total 13byte
- C. Data Frame outputs per second
- D. The number located at 10000 means 10000mm digit number
- E. +/- means above/below zero in temperature. The number located at 10 means 10 degree digit number in °C

Chapter 6 Troubleshooting

This section describes some problem symptoms, with suggestions as to what to do.

Symptom	What to Do
Display blank, transducer not firing.	Check power supply
Display shows "S", " ERROR! LOST ECHO"	"S" means there is an abrupt liquid change or an obstacle in the beam path is detected. Check the obstacle and get rid of it.
Display shows " BOTTOM SET ERROR".	Measuring range is bigger than setting value of maximum range. Go to the option No. 03, and set the bigger bottom distance

Menu Option Record

SLM1000 Series

Option Details		Entered Value					
No.	Description	Factory Set	Value Range	1	2	3	4
01	Password Change	412	0 ~ 1000				
02	Measure Type	Level	Level/Distance/Space				
03	Bottom Distance	8.00/12.00/15.00m	0 ~ 8.00/12.00/15.00m				
04	4mA SetPoint	0.00m	0 ~ 8.00/12.00/15.00m				
05	20mA SetPoint	8.00/12.00/15.00m	0 ~ 8.00/12.00/15.00m				
06	Blanking	0.35m/0.50m	0.35m~/0.50m~				
07	HH On	11.00m	0 ~ 8.00/12.00/15.00m				
08	HH Off	10.00m	0 ~ 8.00/12.00/15.00m				
09	H On	10.00m	0 ~ 8.00/12.00/15.00m				
10	H Off	9.00m	0 ~ 8.00/12.00/15.00m				
11	L On	2.00m	0 ~ 8.00/12.00/15.00m				
12	L Off	3.00m	0 ~ 8.00/12.00/15.00m				
13	LL On	1.00m	0 ~ 8.00/12.00/15.00m				
14	LL Off	2.00m	0 ~ 8.00/12.00/15.00m				
15	Measure Response	2	1,2,3,4				
16	Transmit Power	3 (XDS800/1200)	1~5				
		4 (XDS1500)					
17	Error Current Set	3.8mA	3.8mA/Hold/21mA				
18	Fail Safe Time	120s	20~1800 seconds				
19	Detection Threshold	4 (XDS800/1200)	4~15				
		5 (XDS1500)					
20	Detection Method	First Echo	First/Maximum Echo				
21	Sound Velocity	331.5m/s	200~500m/s				
22	Velocity T Factor	0.6m/°C	-2.0~+2.0m/°C				
23	Material Temp.	25°C	0~100°C				
24	Material T weighting	0%	0~100%				
25	System Unit	Meter	Meter/Feet				
26	12mA Output						